

Flow Dynamics of Dense Granular Materials Subjected to Vertical Vibration

Azita Soleymani,¹ Vesa Tanskanen,¹ Piroz Zamankhan,¹ and William Polashenski, Jr.²

¹Laboratory of Computational Fluid Dynamics, Lappeenranta University of Technology, Finland

²Lomic, Inc., 100 N. Patterson St., State College, PA 16801

Results are presented from a numerical study examining the flow dynamics of dense granular materials in a narrow gap between two concentric cylindrical buckets subjected to sinusoidal oscillation in the vertical direction $z = A\sin(\omega t)$, where the parameter $\Gamma = A\omega^2/g$ exceeds a critical value, Γ_C , above which the system becomes fluidized. Using a recently developed expression for the stress tensor of dense granular materials, a set of conservation equations were derived for the particle and fluid phases interacting via an interfacial drag force. Numerical integration of the equations for the granular material in buckets revealed that above Γ_C , granular materials may exhibit liquid-like behavior and convection can occur creating a heap similar to that previously observed experimentally.

As a means of fluidizing granular materials, vibrated beds are widely used in the solid processing, food, and agricultural industries. In vibrated beds, granular materials behave like both continuous and discrete media [1], yielding interesting phenomena such as heap formation and convective roll patterns [2]. Note that by using relatively small grains, namely $d < 1\text{ mm}$, friction with the container walls can be greatly reduced. For these conditions, the presence of interstitial gas was shown to result in the formation of a heap [3]. Behringer et al. [4] concluded that the vanishing of the heap at low pressure namely 0.01 torr, may be caused primarily due to the onset of a Knudsen regime as well as a lack of a sufficient gas flow to sustain the flow of grains. In light of the above discussion, a model is needed to capture the key role of the ambient gas on dense flows of granular material. Recently within the frame of continuum mechanics, Zamankhan et al. [5] have proposed a model for gas-particle flow in which an effective rate-dependent viscosity was introduced for a slowly deforming dense granular assembly. Their approach could successfully predict

the continuous flow of grains in a spinning bucket at high rotational frequencies, in which an evolution of surface shape from cusp to depression near the axis of rotation was predicted similar to that observed experimentally [5].

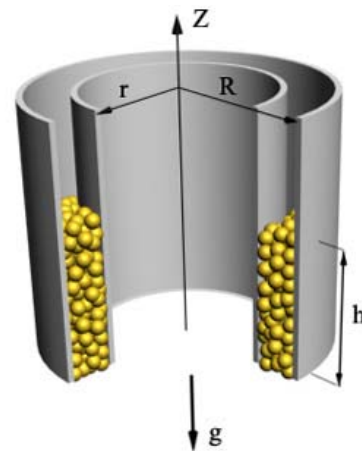

Fig. 1. Cut-away view of three-dimensional dense granular flow in a bucket whose base is subject to vertical sinusoidal oscillation along the Z axis.

In this paper a numerical investigation is presented of the flow dynamics of grains and heap formation in a dense granular bed under vertical vibration, $z = A\sin(\omega t)$, as shown in Fig. 1, using the above-mentioned model described in [5]. The granular materials are composed of rough, inelastic, identical spherical glass particles of diameter $\sigma = 0.2\text{mm}$. The container is sealed and only its base is oscillated. Note that gravity and the vibration act in the direction of the cylindrical axis. As the relaxation in this system is logarithmically slow, the equations have been normalized in order to decrease the simulation time [6].

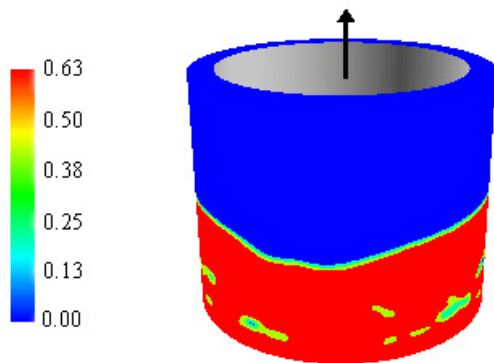

Fig. 2. Contours of the volume fraction of the particle phase resulting from a vertical sinusoidal oscillation $z = A\sin(\omega t)$ of the base of the bucket. Here $\Gamma = 1.30$, the granular mean depth $h = 5\text{ cm}$, $A = 0.534\text{ cm}$ and frequency $f = 7.78\text{ Hz}$.

As Γ is varied, the layer undergoes a backward bifurcation between a solid-like state and a liquid-like state that typically consists of a moving layer of maximum depth H riding on the top of a solid layer [7], as depicted in Fig. 2. For $h/d \gg 1$ where the relevant control parameter, $\Gamma = A\omega^2/g$ is larger than the critical value Γ_{C-h} , steady convective motion evolves in the form of two counter-rotating rolls, downward along the vertical side walls and upward in the middle, leading to a single heap, as depicted in Fig. 2, making a dynamic angle of repose with the horizontal [3].

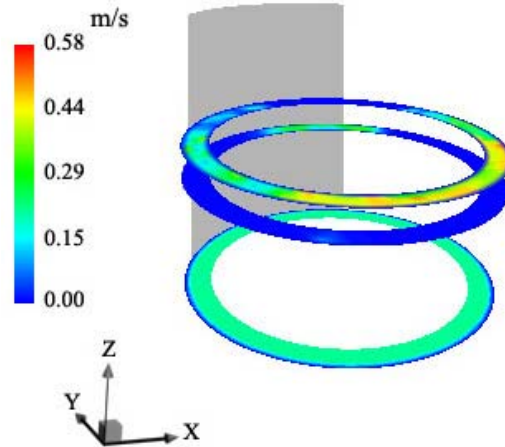

Fig. 3. Contours of particle phase velocity at three different elevations calculated during a numerical simulation. Here $\Gamma = 1.30$, the mean height = 5 cm , $A = 0.534\text{ cm}$ and frequency $f = 7.78\text{ Hz}$.

To conclude, we have shown that by using a rate-dependent effective viscosity for a highly concentrated granular flow, the presence of a heap and convective roll patterns can be predicted at Γ slightly higher than unity. The role of ambient gas is taken into account in our simulation. The sample results are presented for the case in which $\Gamma = 1.30$, $\sigma = 0.2\text{mm}$, the granular mean depth $h = 5\text{cm}$, $A = 0.534\text{cm}$ and frequency $f = 7.78\text{ Hz}$.

- [1] H.M. Jaeger and S.R. Nagel, Science **255**, 1523 (1992).
- [2] H.K. Pak, E. Van Doorn, and R. P. Behringer, Phys. Rev. Lett., **74**, 4643 (1994).
- [3] H.M. Jaeger, S.R. Nagel, and R.P. Behringer, Rev. of Mod. Phys, **68**, 1259 (1996).
- [4] R.P. Behringer, E. Van Doorn, R.R. Hartley, and H.K. Pak, Granular Matter, **4**, 9 (2002).
- [5] P. Zamankhan, W. Polashenski Jr., A. Soleymani, Phys. Rev. E, submitted.
- [6] J.B. Knight, C.G. Fandrich, C.N. Lau, H.M. Jaeger, and S.R. Nagel, Phys. Rev. E. **51**, 3957 (1995).
- [7] G. Metcalfe, S.G.K. Tennakoon, L. Kondic, D.G. Schaeffer, and R.P. Behringer, Phys. Rev. E., **65**, 031302-1 (2002).