

# Chapter 2

## Biomimetic Single-Site Heterogeneous Catalysts: Design Strategies and Catalytic Potential

David Xuereb, Joanna Dzierzak, and Robert Raja

**Abstract** Enzymes catalyze the most fundamental reactions in organic chemistry from simple oxidations of straight chain alkanes to complex C–C bond forming reactions with exceptional selectivity. Mimicking the active site of an enzyme by immobilising a well defined amino acid containing transition-metal centre on a robust inorganic framework, provides a powerful catalyst that can be utilized in the production of fine chemicals and complicated drug molecules. Porous aluminosilicates and mesoporous silicas offer suitable supports for single-site bio-derived catalysts. These materials can be created from a range of methodologies and the different strategies used for immobilisation can greatly affect the nature of the active catalyst. The routes by which these catalysts are immobilised have also given the potential to derivatize inorganic structures with amino acids, not just for complexation to metal centres but for use as organocatalysts as well. These metal free bio-derivatized frameworks offer advantages over their homogeneous counterparts and can carry out stereoselective reactions with great effectiveness. Herein, the routes to heterogenizing biomimetic catalysts will be critically assessed and depending on the methods used, suitable active catalysts for use in chemo- and stereoselective transformations can be developed.

### 2.1 Metalloenzymes

A metalloenzyme is usually a huge protein that contains a small metal complex in the active site. The metal ion is coordinated by a few amino acids from the protein scaffold that stabilizes and isolates the metal active centre as well as providing a specific binding pocket for a substrate (Fig. 2.1). Proteins coordinate to metal ions with nitrogen, oxygen and sulphur containing ligands. Amino, amido,

---

D. Xuereb, J. Dzierzak, and R. Raja (✉)

School of Chemistry, University of Southampton, Highfield, Southampton SO17 1BJ, UK  
e-mail: R.Raja@soton.ac.uk

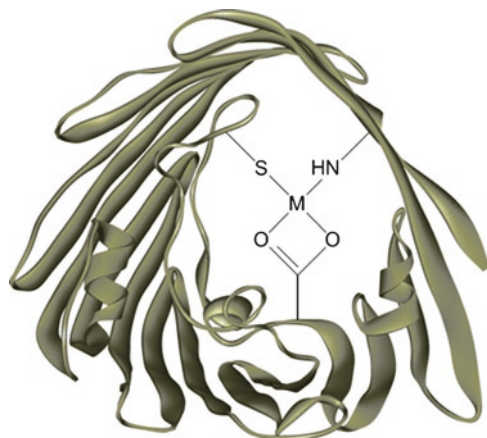

**Fig. 2.1** Schematic representation of metalloenzyme active site

amidato, carbonyl and carboxylate ligands can be located at the C- or N-termini of the peptide chain, within the chain itself (except amino and carboxylate) and in side chain [1].

Iron and copper ions are the most commonly occurring metal centers in biological oxidation systems and play an important role in heterogeneous and homogeneous catalysis, mainly due to their inherent electronic properties and accessible redox potentials. Important examples are haem iron, non-haem iron and copper active sites [2].

### **2.1.1 Iron Enzymes**

Metalloenzymes containing iron active sites comprise a large group of dioxygen activating enzymes that possess potential for functionalizing a wide-range of organic substrates with high efficiency and selectivity [3].

Among heme enzymes activating  $O_2$  cytochrome P450 has received the most attention. P450s play critical roles in the biological hydroxylation of saturated carbon-hydrogen bonds, epoxidation of double bonds, oxidation of heteroatoms and aromatics and dealkylation reactions. The P450 active site consists of an  $Fe^{III}$  porphyrin cofactor covalently linked to the protein backbone through coordination of a sulphur atom of cysteine [4].

Mononuclear non-heme iron enzymes comprise a large collection of dioxygen activating enzymes that are very different from their heme counterparts due to electronic and geometric differences arising from ligand environments. These enzymes catalyse oxidative transformations either by involving high-spin ferrous ( $Fe^{II}$ ) ions or by the utilization of high-spin ferric ( $Fe^{III}$ ) active centres. The  $Fe^{III}$  site is usually utilized to activate substrates for reactions with dioxygen and include intradiol

dioxygenases and lipoxygenases. The  $\text{Fe}^{\text{II}}$  site activates oxygen by direct binding to  $\text{O}_2$ , resulting in iron-oxygen intermediates that react with the substrate and include Rieske dioxygenases, pterin-dependent hydroxylases or extradiol dioxygenases [5].

Binuclear iron enzymes involved in  $\text{O}_2$  activation primarily exist in two oxidation states: the fully reduced bi-ferrous  $[\text{Fe}^{\text{II}}]_2$  and the oxidized bi-ferric  $[\text{Fe}^{\text{III}}]_2$  form. A particular example of a di-iron containing enzyme is soluble methane monooxygenase (sMMO) which consists of a carboxylate-bridged dinuclear iron centre [4] that is capable of producing oxygen species of much superior activity than other monooxygenases. In addition to aromatics and other compounds, MMO exhibits a unique ability to convert even methane, which is known to be the most inert hydrocarbon (C–H bond energy, 104 kcal/mol), into methanol using dioxygen as the oxidant via  $[\text{Fe}^{\text{III}}]_2$ -peroxo and  $[\text{Fe}^{\text{IV}}]_2$  intermediates [6]. One oxygen atom is reduced to water, and the second is incorporated into substrate molecule, yielding the alcohol.

### 2.1.2 Copper Enzymes

Copper active sites play a major role in biological dioxygen activation systems [7]. Copper containing enzymes are involved in hydroxylation reactions (particulate methane monooxygenases pMMO, tyrosinase), reversible dioxygen binding (hemocyanin), two-electron reduction of  $\text{O}_2$  to peroxide coupled with oxidation of organic molecules (galactose oxidase GO) and four-electron reduction of  $\text{H}_2\text{O}_2$  to water while oxidizing the substrate (ascorbate oxidase).

Particulate methane monooxygenase (pMMO) contains copper in the active site, similar to diiron sMMO because it also catalyses the oxidation of methane to methanol. pMMO contains a mononuclear copper active site together with a dinuclear copper site, but the structure, mechanism and actual reaction site for the methane hydroxylation has not been identified due to difficulties in isolation of sMMO [8].

Galactose oxidase (GO) contains one copper atom per active centre. The active site involves residues of four amino acid side chains (two histidine and two tyrosine amino acids) directly coordinated to a mononuclear Cu centre, which is also bound by a solvent molecule to form a distorted five-coordinate metal complex. Galactose oxidase catalyzes the two-electron oxidation of primary alcohols to aldehydes, which in turn can serve as substrates to yield carboxylic acids. During the catalyzed reaction, the enzyme alternates between three different forms: an active, inactive, and fully reduced form. In the active form of GO, the tyrosine is in a radical form and the copper atom with a oxidation state +2 [9,10].

Tyrosinase and catechol oxidase contain a binuclear copper centre as the active site. The dicopper (I) active site in these enzymes react with  $\text{O}_2$  to generate a (per-oxo) dicopper (II) unit that is responsible for the oxidation of phenols and catechols. Both enzymes can oxidize catechol to quinone, but only tyrosinase can hydroxylate phenol [11,12].

## 2.2 Amino Acids

Amino acids are highly functional molecules that are protein constituents (Fig. 2.2). An amino acid is composed of a basic amino functional group ( $-\text{NH}_2$ ), acidic carboxyl functional group ( $-\text{COOH}$ ), a hydrogen atom and a characteristic side chain ( $-\text{R}$ ) giving a general formula  $\text{R}-\text{CH}-\text{NH}_2-\text{COOH}$ .

At high pH the carboxyl group tends to be dissociated, giving the molecule a stronger negative charge. At low pH the amino group is protonated therefore giving the molecule a net positive charge. At the isoelectric point the amino acid in solution has a net charge of zero that contains positively and negatively charged substituents in equal quantities, this state is called a zwitterion (Fig. 2.3).

Amino acids are good metal-complexing agents, forming chelate rings through the amino and carboxylate groups via dissociation of the acidic proton as a bidentate N,O-donor (Fig. 2.4). A side chain e.g. phenol ring of tyrosine, imidazole

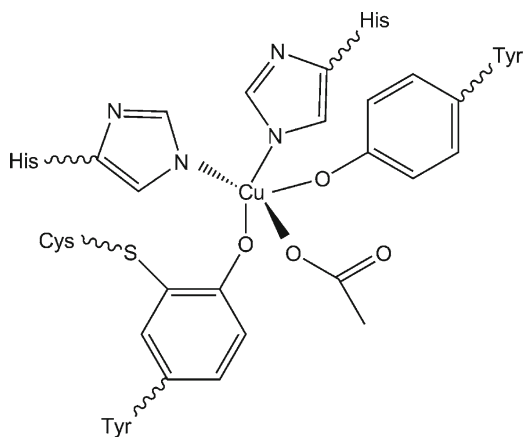

Fig. 2.2 Galactose oxidase active site

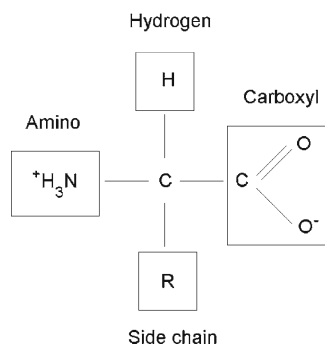
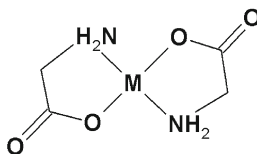
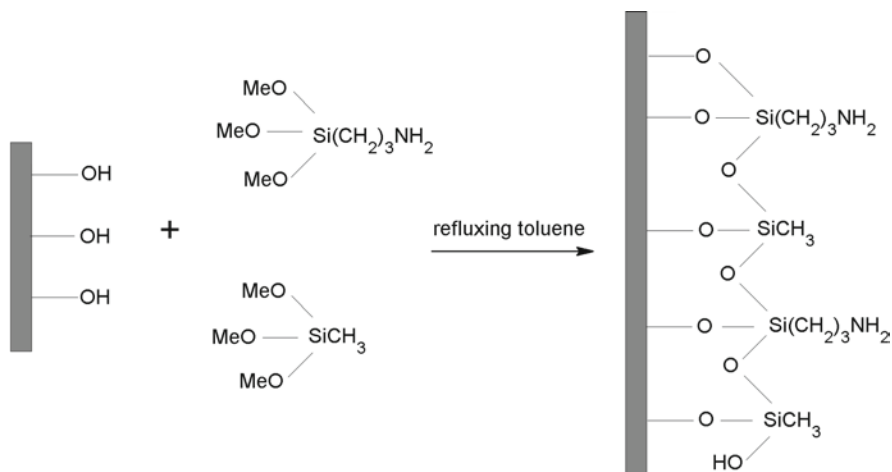

Fig. 2.3 Generalized structure of a typical amino acid





**Fig. 2.5** General structural formula proposed for amino acid complexes



**Fig. 2.6** Model of the surface sites in functionalized silica

a methodology called solid phase peptide synthesis (SPPS) (Fig. 2.6). The hydrophobic character inside the pores can be adjusted by co-functionalization with other species e.g. methyl groups [19]. Amino acids can be covalently anchored onto the support by the formation of very stable amide bonds with surface bound amide groups. Amine functionalized materials can be prepared by post synthetic grafting of 3-aminopropyl-trimethoxysilane on a silica surface, or by co-condensation of 3-aminopropyl-trimethoxysilane with a silica precursor [20]. The material with only the 3-aminopropyl moieties shows a poor hydrothermal stability. The reason for this is due to the basicity of the functional groups and the fast hydrolysis of the silica in the presence of an amine. Silica surfaces that are functionalized with a mixture of methyl groups and 3-aminopropyl groups are more stable. The hydrothermal stability improves by decreasing the amount of 3-aminopropyl bound to the silica surface. This is due to a decreasing basic character inside the pores and also because the silica is protected from hydrolysis when hydrophobic methyl groups are present together with 3-aminopropyl groups.

Solid phase peptide synthesis (SPPS), developed by Merrifield et al. [21], was a major breakthrough allowing the chemical synthesis of peptides and small proteins that can be bound to an insoluble support and any unreacted reagents left at the end of the synthetic step can be removed by a simple washing procedure.

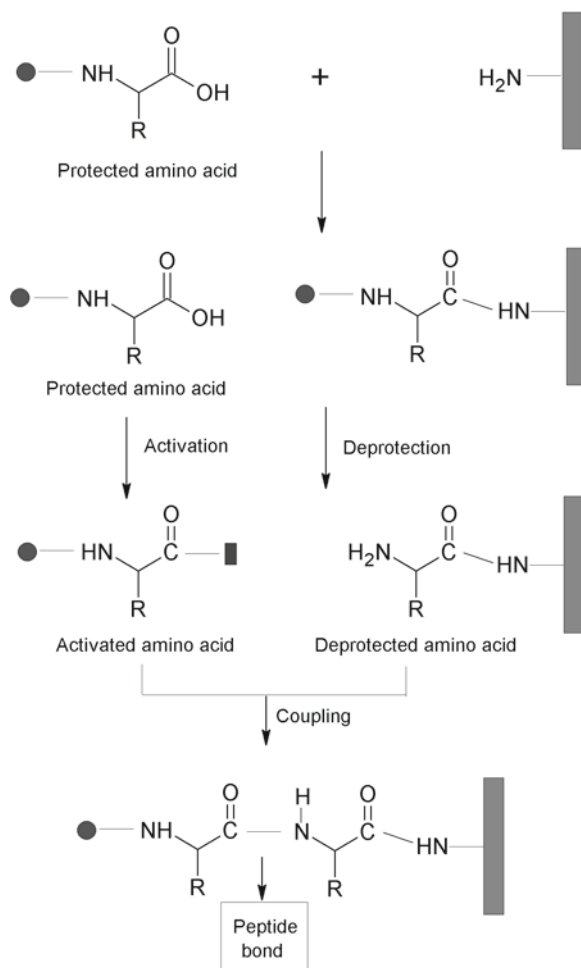
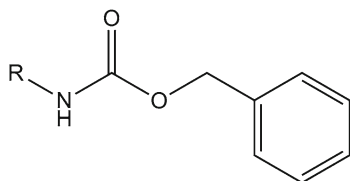

**Fig. 2.7** Scheme for solid phase peptide synthesis (SPPS)

SPPS comprises of repeated cycles of coupling and deprotection of successive amino acids (Fig. 2.7). Unlike ribosome protein synthesis, SPPS proceeds in a C N terminal fashion. The free N-terminal amine of a solid-phase attached peptide is coupled to a single N-protected amino acid (Fig. 2.8). This unit is then deprotected, revealing a new N-terminal amine to which a further amino acid is attached.

There are two major termini used in solid phase peptide synthesis, which are Fmoc (base labile alpha-amino protecting group) and t-Boc (acid labile protecting group). Each method involves different protection, deprotection and cleavage steps. To remove Fmoc from peptide chain, basic conditions are used (usually piperidine in DMF), to remove t-Boc, acidic conditions are used (usually trifluoroacetic acid).

● N-terminus protecting groups



Cbz-(benzylcarboxy) carbamate

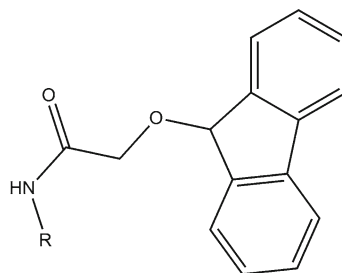

Fmoc-(9-fluorenylmethyl) carbamate

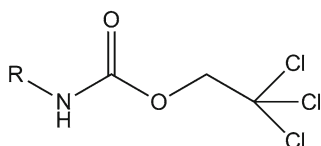

Troc-(trichloroethyl) carbamate

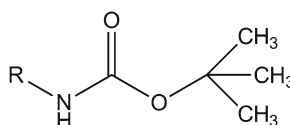

Boc-(tButyloxy) carbamate

C-terminus protecting groups

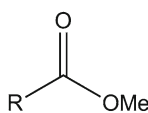

Me-(methyl) ester

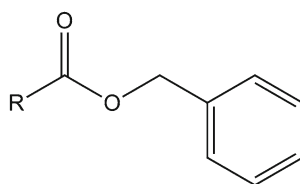

Bn-(benzyl) ester

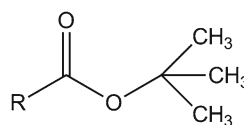

tBu-(tert butyl) ester

■ Activating groups

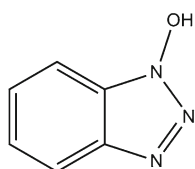

HOBT-1-hydroxy-benzotriazole

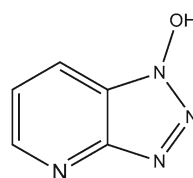

HOAt-1-hydroxy-7-aza-benzotriazole

**Fig. 2.8** Examples of activating and C-, N-terminus protecting groups in SPPS

When coupling a carboxyl group of an amino acid, it is activated thereby making the reaction proceed at a much faster rate. There are two main types of activating groups: triazolols (HOBT, HOAt) and carbodiimides (DCC, DIC). Fmoc chemistry has many advantages over t-Boc chemistry as it generates peptides of higher quality and in better yield.

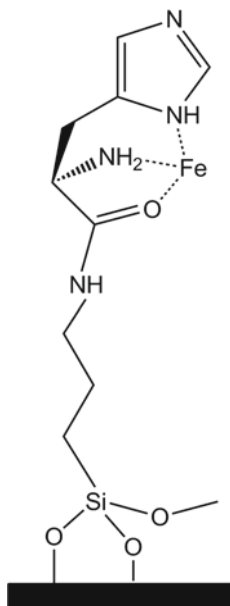

**Fig. 2.9** Model of iron complexation by histidine on amino functionalized silica

A number of amino acids and short peptide complexes with iron and copper have been immobilized on mesoporous silica via SPPS and these have shown promising trends in the oxidation of hydrocarbons [22], an example is shown in Fig. 2.9.

### 2.3.2 *Amino Acid Transition Metal Complexes Encapsulated Within Zeolites*

Zeolites are crystalline aluminosilicates with a three-dimensionally connected pore structure. The zeolite framework consists exclusively of corner-sharing  $\text{AlO}_4$  and  $\text{SiO}_4$  tetrahedra. The primary building units are single  $\text{TO}_4$  tetrahedra, where the T atom is an aluminium or silicon atom. Each T atom is tetrahedrally bonded to four oxygen atoms forming a bridge to neighbouring T atoms. Silicon surrounded by four oxygen atoms (essentially  $\text{SiO}_2$ ) has no charge. Aluminium has  $3^+$  charge, thus  $\text{AlO}_2$  has a net negative charge. The charge imbalance between Si and Al results in an overall net negative charge on the zeolitic framework. The presence of aluminium produces this negative charge and is balanced by non-framework cations that can be readily exchanged [23].

Zeolites have the ability to act as catalysts for chemical reactions which take place within their internal cavities. They are thermally stable, chemically robust and easy to separate from the reaction products. Zeolites can incorporate and immobilize

various active sites within their structure in the channels and cages. Careful combination of metal complexes immobilized as active sites in an inorganic matrix can result in catalysts that can mimic the functional aspects of enzyme activity [24,25]. Zeolites are ideal supports and by judicious choice of the active site novel single-site heterogeneous catalysts can be designed [26,27]. Such zeolite encapsulated active centres present many advantages. Zeolites have well organized pores and channels, which readily serve as supporting hosts for various molecules. In such systems zeolites can serve as a substitute for the protein mantle of natural enzymes and provide a controlled steric environment, where the catalysis ensues [28,29]. These heterogeneous catalysts are resistant to harsh reaction conditions, more stable at high temperatures, facilitate separation of products from reactants and aid catalyst recyclability.

Several general routes [30] are known for preparation of metal complexes inside zeolites:

- Ion Exchange – Exposing a sodium ion charge balanced zeolite to a solution containing other cations facilitates exchange of the sodium ions. This method has been used for encapsulating metal–amino acid complexes inside a zeolite structure [31].
- Flexible Ligand Method – Synthesis of the metal complex in situ in the zeolite cavity by reaction of the ligand with the exchanged metal cations. Complexes with previously exchanged metal ions are able to diffuse freely through the zeolite pores. This approach is well suited for the encapsulation of metal–salen complexes, as the salen ligand offers the desired flexibility [32].
- Ship in the Bottle – The final molecule is prepared inside the pores by reacting smaller precursors to afford the larger molecule ‘mechanically entrapped’ inside the cages. This route was employed for metal–phthalocyanine or metal–porphyrin complexes within the zeolite [33].
- Zeolite Synthesis Method – ‘Templated’ Synthesis Synthesis of the zeolite in the presence of the preformed metal complexes. Transition metal complexes which are stable under the conditions of zeolite synthesis are included in the synthesis mixture. Metal phthalocyanines, porphyrins and amino acids provide examples of such encapsulated catalysts [34].

The first stable and catalytically active example of zeolite immobilized transition metal complex containing amino acid ligands is Cu-Histidine synthesized by the ion exchange method [35]. In the first stage of this method zeolite Y exists in its  $\text{Na}^+$  form by successive ion exchanges with NaCl solution. The next step is to ion exchange with a solution of Cu-Histidine at pH 7.3. An AA:  $\text{Cu}^{2+}$  ratio of 5 is needed because lower ratios give partial hydrolysis of  $\text{Cu}^{2+}$ , which manifests above pH 6. The ability of the Cu-Histidine to undergo ion exchange is dependent on its charge and stability, which are influenced by the pH. At pH 2 only 0.83% of the  $\text{Cu}^{2+}$  is coordinated to His. At pH 3,  $\text{Cu}^{2+}$  forms *mono*-His complexes, whereas in the pH range 6–10, *bis* complexes are formed. In *bis* complexes, four nitrogens,  $\text{N}_{\text{am}}$  and  $\text{N}_{\text{im}}$ , of each molecule as well as carboxylate oxygen can coordinate to the metal. It was found that, in solution, two histidine ligands coordinate to the  $\text{Cu}^{2+}$  ion

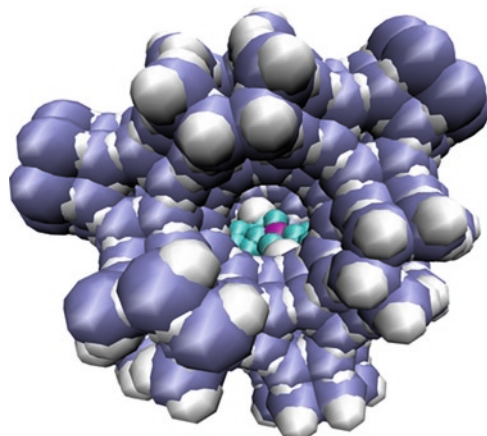

**Fig. 2.10** Graphical representation of an Fe–proline complex in its energy-minimized configuration anchored within the supercages of zeolite X

in a square-planar geometry. However, upon encapsulation within the channels and cages of zeolite Y, by the ion-exchange method, a framework oxygen atom replaces one of the histidine ligands.

Another example is an Fe<sup>3+</sup>-Proline complex that was immobilized within the supercages of the zeolite Faujasite by using zeolite synthesis methodology, in which the zeolite was synthesized in presence of preformed Fe<sup>3+</sup>-Proline complexes (Fig. 2.10).

Typical XRD patterns of Fe<sup>3+</sup>-Proline complexes encapsulated within zeolites X and Y reveal identical patterns reported for the neat zeolites [36]. Well-resolved peaks with no phase impurities indicate that the Faujasitic architecture is structurally unaltered after the encapsulation procedure. The absence of additional structural reflections due to the neat complex confirms its dispersion predominantly within the internal cages and not on the external surface.

The FTIR spectra of Fe<sup>3+</sup>-Proline encapsulated within zeolite X (shown in Fig. 2.11, along with the assignments for the various bands) provides spectroscopic information on the nature and structural integrity of the encapsulated amino acid ligand. The presence of a strong band at 1662 cm<sup>-1</sup> for Fe<sup>3+</sup>-Proline-X and neat Fe-Proline, coupled with the absence of signal around 1750 cm<sup>-1</sup>, which is typical of the COOH species, confirm that the carboxyl group is deprotonated. The carboxylate ions can be readily characterized by an antisymmetric ( $\nu_{as}$  COO<sup>-</sup>) and a symmetric stretching mode ( $\nu_s$  COO<sup>-</sup>), around 1,650 and 1,400 cm<sup>-1</sup>, respectively [37]. As for the amino group, the  $\nu_{N-H}$  bands of neutral N-H groups can be seen at 3,285 cm<sup>-1</sup> for Fe<sup>3+</sup>-Proline-X, and at 3,210 cm<sup>-1</sup> for neat Fe<sup>3+</sup>-Proline (corresponding bending  $\delta_{N-H}$  vibration can be observed at 1,375 and 1,345 cm<sup>-1</sup> respectively). In Fe-Proline<sup>3+</sup>-X, these bands can be readily superimposed to a broad signal in the 3,700–2,800 cm<sup>-1</sup> interval, which can be attributed to the hydrogen bonding between proline and zeolite. The absence of the  $\delta NH_2^+$  vibration at 1,550 cm<sup>-1</sup> is

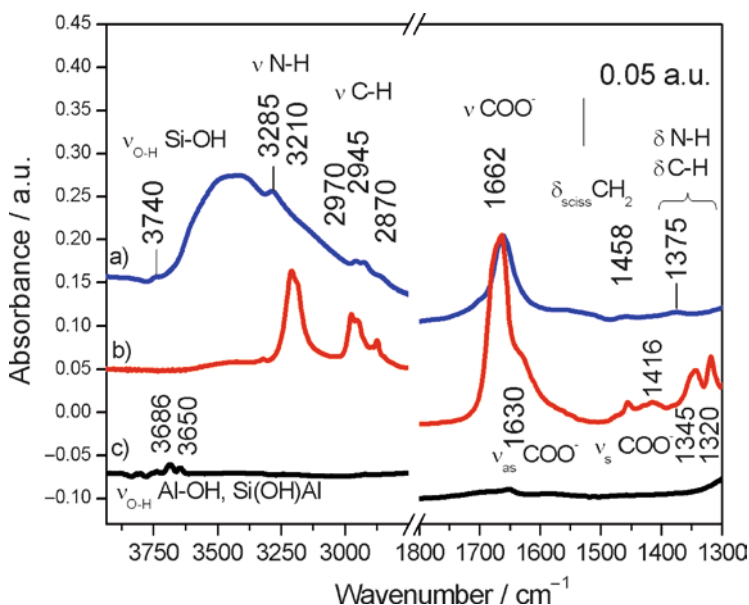

**Fig. 2.11** FT-IR spectra of Fe<sup>3+</sup>-Proline-X (a), Fe<sup>3+</sup>-Proline (b), Zeolite X (c)

**Table 2.1** Surface area and pore volume measurements for the neat zeolite X and zeolite encapsulated Fe<sup>3+</sup>-Proline-X catalyst

Catalyst	BET surface area (m <sup>2</sup> /g)	Micropore volume (cm <sup>3</sup> /g)
Fe <sup>3+</sup> -proline-X	85.3	0.04
Zeolite X	620.8	0.09

conspicuous, which confirms that the amino group is not protonated and can play a role in complexing with the iron sites.

Significant decrease in the internal pore volume and surface area for the encapsulated materials strongly indicates the presence of the Fe<sup>3+</sup>-Proline complex within the supercages of the Faujasite structure (Table 2.1).

DR UV-Vis elucidates the nature of Fe species encapsulated within zeolites (Fig. 2.12). The heterogeneous Fe<sup>3+</sup>-Proline based catalyst showed a band at 37,600 cm<sup>-1</sup> and a more predominant band at 45,400 cm<sup>-1</sup>. This component at higher wavenumber (45,400 cm<sup>-1</sup>) can be assigned to well-dispersed and isolated Fe<sup>3+</sup> sites [38].

The Electron Paramagnetic Resonance (EPR) spectrum of the Fe<sup>3+</sup>-Proline-X consist of broad resonance line at  $g = 2$  together with a narrow signal at  $g = 4.26$ . It is highly likely that such signals originate from strongly interacting Fe<sup>3+</sup>-Proline centers located near the extremities of the cages of zeolite X [39].

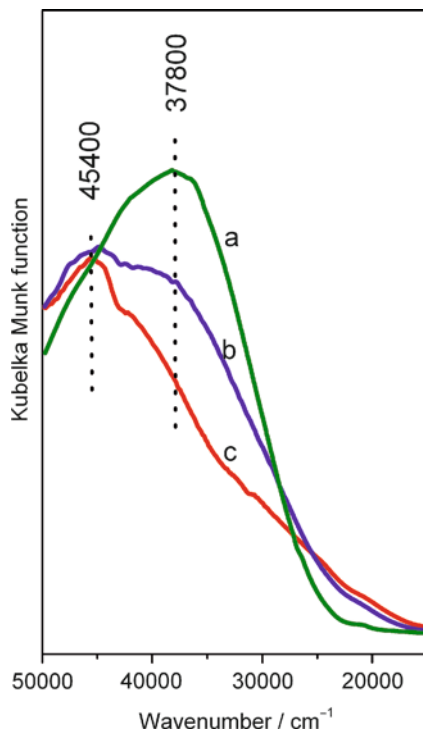

Fig. 2.12 DR UV-Vis spectra of Fe<sup>3+</sup>-Proline (a), Fe<sup>3+</sup>-Proline-Y (b), Fe<sup>3+</sup>-Proline-X (c)

### 2.3.3 Catalysis

The selective oxidation of hydrocarbons and benzylic alcohols by molecular oxygen continues to pose a major challenge in the synthesis of commodity and fine-chemicals [40,41]. Transition-metal complexes containing amino acids encapsulated within solid supports generate isolated active centers that function as effective selective oxidation catalysts using benign oxidants such as air and display high turnovers and selectivity in industrially significant oxidation reactions (Table 2.2).

Encapsulated Cu-Histidine showed promise as a catalyst for oxidation of cyclohexene and was 89 mol% selective towards 1,2-cyclohexanediol.

The encapsulated Fe<sup>3+</sup>-Proline showed catalytic potential in the selective oxidation of cyclohexane and benzyl alcohol. The oxidation of cyclohexane revealed interesting changes in activity and selectivity when O<sub>2</sub> was employed as the oxidant. The encapsulated Fe<sup>3+</sup>-Proline, gives selectivity towards cyclohexanone (99.5 mol%) with O<sub>2</sub>, but when tert-butyl hydroperoxide (TBHP) was used as the oxidant cyclohexanol was the major product observed. Fe<sup>3+</sup>-Proline-X catalyst showed to be 99+ mol% selective towards benzaldehyde. Cyclohexanone, which is an industrially important commodity chemical and a vital precursor in

**Table 2.2** Catalytic performances of amino acid based catalysts encapsulated in zeolites

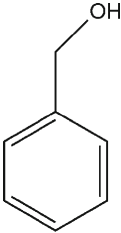
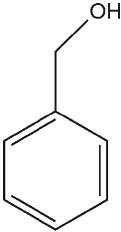
Substrate	Catalyst	Oxidant	Time (h)	TON
	Fe <sup>3+</sup> -proline	O <sub>2</sub>	6	356
	Fe <sup>3+</sup> -proline	TBHP	6	550
	Fe <sup>3+</sup> -proline	O <sub>2</sub>	1	56
	Fe <sup>3+</sup> -proline	TBHP	1	1,283

the manufacture of  $\epsilon$ -caprolactam (for nylon-6) and adipic acid (for nylon 6,6) can be produced in high selectivities using benign oxidants and zeolite-encapsulated amino acid complexes. These benign and green catalysts have shown potential in the oxidation of benzylic alcohols with high selectivities for the corresponding aldehydes. The presence of well-defined and isolated single-sites, coupled with the hydrophobicity/hydrophilicity of the host results in the generation of a powerful functional biomimetic system.

### 2.3.4 Summary

Bio-molecules such as amino acids immobilized within inorganic host materials attract considerable attention for applications in catalysis. Zeolites and mesoporous silicas are ideal supports for generating single-site heterogeneous catalysts. Transition metal complexes containing natural amino acid ligands can be immobilized as active sites in such supports. The obvious advantages are that such heterogeneous catalysts are highly resistant to harsh reaction conditions, stable at high temperatures, facilitate separation of products from reactants and improve catalyst recyclability. Not only can these heterogenized amino acids serve as ligands that coordinate to metal centres but can individually act as organocatalysts and be active in some of the most fundamental organic transformations.

## 2.4 Routes to Heterogeneous Organocatalysts Through Amino Acid Immobilization

The use of organic molecules as catalysts has gained much exposure in recent years, so much so that it is now a predominant area in organic chemistry, recognised as *organocatalysis*. Amino acids have been identified as organocatalysts especially that of L-proline, which has been effective in catalysing a range of transformations such as aldol reactions [42], Diels-Alder reactions [43] and Mannich reactions [44]. Employing organocatalysts has many shortcomings due to their homogeneous nature, which necessitates the use of high mol% of catalyst and gives rise to difficulties associated with recovery and reusability. Through immobilisation these downfalls can be suitably overcome and could even lead to increased selectivity. There are various reasons for this increased selectivity accredited to the influence of the steric constraints present in some particular supports or because of the stability the catalyst receives, consequently inducing an affect on the mechanism or the transition state.

Herein, different approaches for immobilisation will be reviewed, with a focus on the methodologies employed for covalent anchoring of amino acids to mesoporous silica. The benefits of heterogenisation will become apparent on evaluation of the catalytic potential.

### 2.4.1 Choice of Support

Two general concepts used for amino acid immobilisation are by covalent and non-covalent methods (Fig. 2.13). There are a number of support types for each method and the choice of which form is usually based on the inherent properties of the support and the benefits that it can offer.

Careful consideration must be taken regarding the stability of the support, especially that of extreme temperatures and pH, so that a basis of selection can be made.

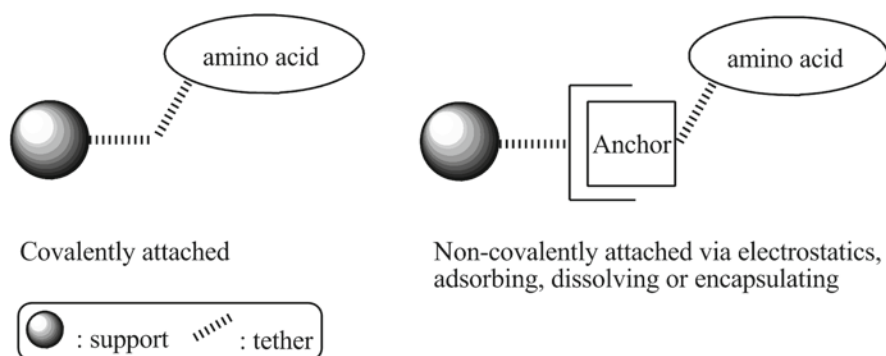

Fig. 2.13 A representation of the two distinct methods of immobilisation

Solubility factors and solvent versatility also play an important role in deciding upon the nature of the support, as these are vital in fulfilling the optimum reaction conditions. Other aspects such as the hydrophobic/hydrophilic nature or steric and electrostatic interactions that may be present must be evaluated to anticipate if this would thwart or assist successful reactions. Immobilised amino acids will serve as active organocatalysts, so the reaction mechanism by which the transformation proceeds must be understood. Specific ‘parts’ of the supported organic catalyst must be accessible to reactants e.g. when using an amino acid as a catalyst for the asymmetric aldol reaction the amino and carboxylate functionalities must be free for enamine formation and transition state arrangement respectively. In this case, immobilisation by covalent methods must occur through the side-chain so that the reaction mechanism is not hindered in any way.

Covalently anchored catalysts can be separated into two categories based on the solubility: soluble supports, including PEG and dendrimers, and insoluble supports such as silica and polymers. Examples of non-covalently attached catalysts are immobilisation on ionic liquid modified-silica matrices and encapsulation inside the cavities of  $\beta$ -cyclodextrin. These are not the only types of support that are available and supports that have not been mentioned but have had much attention are biphasic catalysts, whereby amino acids are anchored to ionic liquids [45]. The ionic liquid moiety can act as a soluble support and an advantage of using this route is that the catalyst can be recovered simply by the solubility difference with varying solvents. These catalysts, however, are not heterogeneous and will therefore not be discussed here.

## 2.4.2 *Non-covalent Catalysts*

These catalysts are not chemically bound to the support but give remarkably strong attachment through attractive interactions between the catalyst and the framework [46].

### 2.4.2.1 $\beta$ -Cyclodextrin and Ionic-Liquid Matrices

A striking example of a non-covalently bound catalyst is an L-proline derivative that has been successfully immobilised within  $\beta$ -cyclodextrin [47].

This was achieved by inclusion of the phenol moiety branched from the 4-position on the proline ring (Fig. 2.14). Synthesis of the heterogeneous active catalyst was effortlessly accomplished by heating the phenoxy-amino acid and  $\beta$ -cyclodextrin in a mixture of ethanol and water followed by removal of the solvent. The (4*S*)-phenoxy-(*S*)-proline immobilised catalyst proved to be active in catalysing the asymmetric aldol reaction of various benzaldehydes in good yield and with impressive enantioselectivities. Not only was the catalyst easily recovered by filtration and recycled with no loss of selectivity, but the ease with which the active catalyst was immobilised is

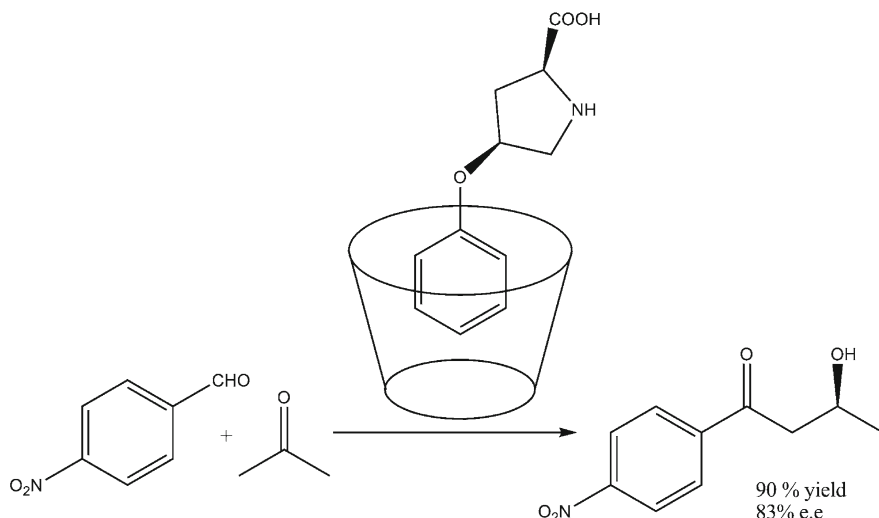

**Fig. 2.14** Amino acid immobilised by inclusion into  $\beta$ -cyclodextrin and an example of the asymmetric aldol reaction it catalysed

most noteworthy. This methodology can be applied to other organic moieties used in catalysis, as demonstrated, in the immobilisation of other proline derivatives [48].

A very different route to non-covalent immobilisation is the adsorption of amino acids onto ionic liquid matrices (Fig. 2.15). These are frameworks that consist of a support such as silica gel with anchored ionic liquids at the surface. These layers provide a location for amino acids to adsorb and dissolve. Modified silica gels have been prepared [49,50] and have been successful in catalysing the aldol reaction between acetone and various aldehydes with modest yields.

The choice of support, i.e. the presence and which ionic liquid was immobilised greatly affected the enantiomeric excess. It was also found that the optimum state of the silica gel for catalysis is when the surface is covered entirely with a covalently attached monolayer instead of a mixture of covalently linked and adsorbed ionic liquid fragment. These results demonstrate the consequences of interactions from the support and the active single-site on the transition state in the asymmetric aldol reaction.

### 2.4.3 Covalently Anchored Catalysts

These catalysts offer advantages over non-covalent analogues such as an increased stability in harsher reaction conditions due to the stronger bonding forces between support and catalyst. Better stability predicts an improved re-usability since in theory, with a stronger attachment, there would be less aggregation and loss of single-site nature.

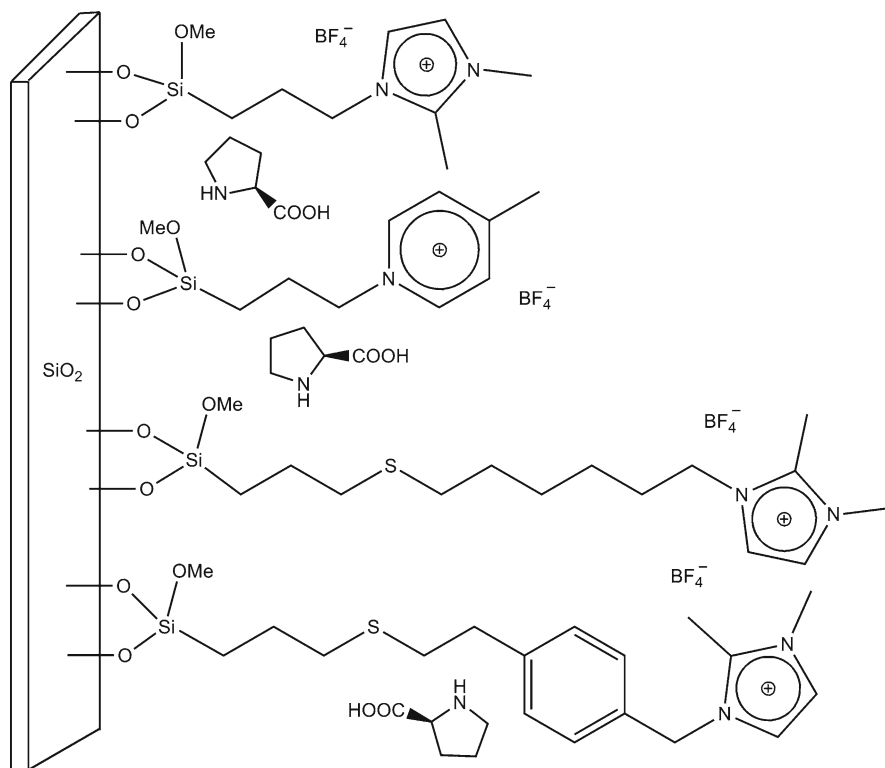

**Fig. 2.15** Ionic liquids covalently attached to silica gels as supports for amino acid immobilisation

### 2.4.3.1 Dendrimers and PEG Supports

As mentioned previously dendrimers are examples of these types of supports and are straight forwardly synthesised using commercially available materials such as diaminobutane poly(propyleneimine) dendrimers  $\text{DAB(AM)}_n$  containing  $n = 4, 8, 16, 32$  or  $64$  free amino groups. The surface amine groups are coupled with carboxylic acid functionalised protected amino acids to give the dendrimer-supported amino acid [51]. A varying number of generations can be synthesised and results indicate that shorter reaction times and lower mol% of catalyst used were benefits accredited to immobilisation. Improvements are also observed with amino acid immobilisation on polyethylene glycol (PEG) [52,53]. PEG supports are high molecular weight (in the order of 1,000s) repeating organic chains; these are linked to the amino acid by a spacer to give a bio-derived organocatalyst. Using this support provides an easy way for recovery of the catalyst by precipitation on addition of a non-polar solvent. PEG and dendrimer amino acid supports are soluble and therefore homogeneous. Not only do these catalysts possess disadvantages like

decreasing activity on recycling but their inherent nature presents drawbacks such as the need for treatment steps.

### 2.4.3.2 Polystyrene

Heterogeneous catalysts offer solutions to problems of recovery and reusability with silica and polystyrene being the most common forms of covalent supports. Amino acids covalently attached to insoluble polystyrene can be recovered by basic filtration. There are numerous strategies for immobilisation; new developments involve 1,3-dipolar cycloaddition of an azide functionalised resin and an *O*-propargyl hydroxy amino acid [54] (Fig. 2.16, e.g. 1) or an even more recent method for synthesising a styrene amino acid derivative that links to a polymer through sulphur via a radical reaction [55] (Fig. 2.16, e.g. 2).

The immobilised proline catalysts were active in the asymmetric aldol reaction for a range of ketones and arylaldehydes and example 2 shown in Fig. 2.16 was also successful in carrying out a variety of  $\alpha$ -selenenylation reactions [55].

Apart from just individual amino acids being immobilised, small peptide chains have also been anchored onto insoluble polymer resins. Di- and tripeptides are highly active and selective catalysts for asymmetric aldol reactions [56,57] and have been found to be more active than homogeneous proline [58]. Peptides are appealing catalysts because they are less complex as enzymes and are attractive alternatives to small organocatalysts, as they offer many more sites for structural and functional variations [57]. Solid supports for peptides include polyethylene glycol grafted on cross-linked polystyrene (PEG-PS). PEG-PS is a practical support because of its compatibility with a range of solvents, due to its amphiphilic nature [59], and its wide use in solid-phase peptide synthesis, which is the method of immobilisation employed for these peptides. This resin-anchored catalyst is highly beneficial especially when the peptides are hydrophobic because the hydrophilic PEG branch of the support now makes the peptide soluble and stops aggregation.

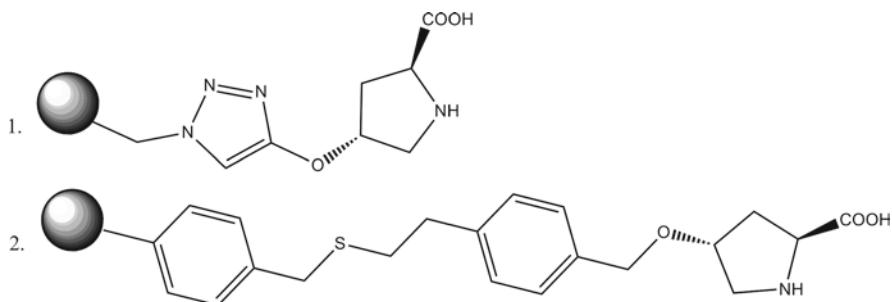
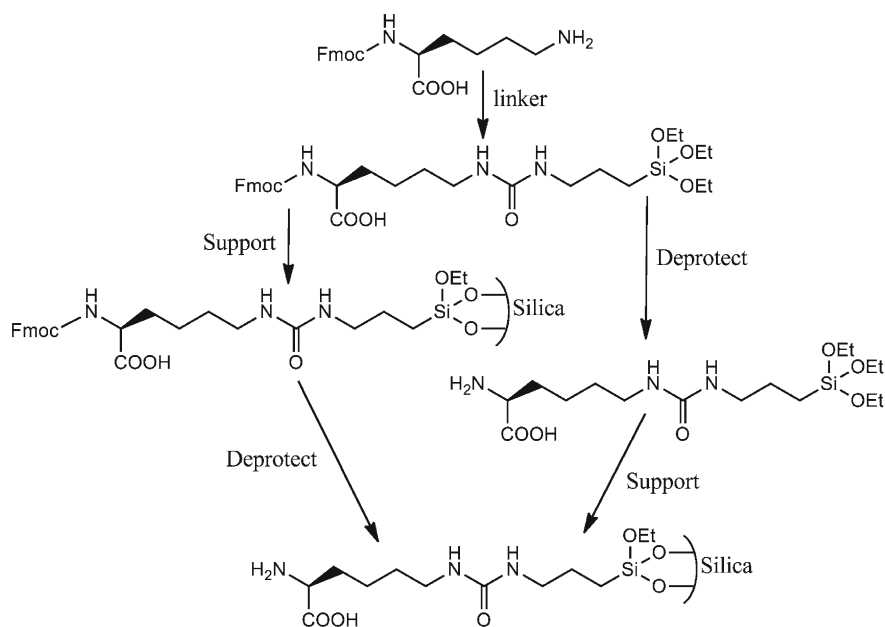

Fig. 2.16 Examples of amino acids covalently immobilised to insoluble resins

### 2.4.3.3 Porous Silica Supports

More recent work has been concentrated on the synthesis of bio-derived silica frameworks. Metal-based catalysts can be covalently anchored into the pores of mesoporous materials most effectively by the post-grafting method [60,61] through anchoring of the organic ligands present. This strategy can be applied to purely organic moieties where chiral catalysts can be introduced onto the surface via a linkage produced by reaction with the silanol functionalities in the channels. This covalent route to immobilisation of organocatalysts is believed to be the most suitable, since adsorption and ionic methods lead to a decrease in catalyst stability. Amino acids used in catalysis must have the amino and carboxylate groups accessible to fulfill the requirements of the well defined mechanism for each particular reaction that the amino acid is catalyzing. Therefore amino acids are immobilised by reacting the functionalities present on the side chain with a linker that can be covalently attached to the silica surface. This was achieved by Calderon et al. whereby the characteristic amino acid side chain is converted into an amine functionality, which undergoes nucleophilic attack of an isocyanate derivatized silane that can then covalently anchor to a silanol group in the channel of porous silica [62]. Three different methodologies can be followed to covalently anchor amino acids on a silica surface, each approach having its own advantages and disadvantages. The two routes shown in Fig. 2.17 are very similar; comprising of the same



**Fig. 2.17** Route (i) and (ii) for the immobilisation of the amino acid L-lysine on porous silica from the starting material Fmoc-Lys-OH

first step of producing an amino acid coupled to an oxy-silane through a urea linkage. The other method couples the amino acid to the linker after the silica has been derivatized with the tether.

- (i) In the first route, the protected amino acid is reacted with a linker; in this case an isocyanate silane. The isolated product is attached to the silica surface under reflux and purified via soxhlet extraction and numerous washings. The amino acid undergoes Fmoc cleavage to leave an accessible amino acid derivatized silica framework ready for catalysis.
- (ii) The second route repeats the first step in method one by reacting the protected amino acid with the linker. After this step the amino acid is deprotected in solution before immobilisation. The product from this stage is anchored to give the single-site heterogeneous catalyst.
- (iii) The third method of heterogenization begins with the attachment of the linker to the framework to construct a functionalized silica surface. The protected amino acid couples with the fixed linker and transfers from being dissolved in solution to being connected to the solid phase. Lastly the immobilised amino acid is deprotected by Fmoc cleavage to leave available amino and carboxylate groups for catalysis.

The first route (i), appears to be more employable than the second (ii), because of the need for less separation and work up steps. This can be problematic when dealing with the silane groups because of the reactivity towards water and the affinity to react with one another to form Si–O–Si bonds. The less work done in solution the better, so by anchoring the product formed in the first step before deprotection, means that only one product has to be isolated in solution. The products in other steps can be isolated by simple filtration because of the solid phase. In this instance the first route is also more appropriate than the third method mentioned above because amino acids are difficult to dissolve. If the linker is already attached inside a pore then the amino acid will not couple to it since it is not in solution and therefore cannot diffuse throughout the framework. To help characterise the reaction between Fmoc-Lys-OH (protected amino acid) and 3-(triethoxysilyl)propyl isocyanate (linker) numerous reactions were carried out with varying primary amines such as benzylamine and propylamine to help give a handle on the shifting of the CH<sub>2</sub> environment neighbouring the urea linkage. The shift was measured at around 0.5 ppm down field. This outcome matches the shift noticed in the <sup>1</sup>H NMR spectrum of the product of the first step which is the reacted Fmoc-Lys-OH. There was a possibility that the acid functionality of the protected amino acid could also undertake nucleophilic attack of the isocyanate linker, but this was not considered after a reaction with the isocyanate tether and  $\gamma$ -aminobutyric acid showed only one product formed. This was proven by the detection of only two inequivalent carbonyl <sup>13</sup>C environments in the NMR spectrum.

Various silica frameworks can be used as supports and these give differing results on enantiomeric excesses and yields. Silica supports can have high or low surface areas, be porous or non-porous and have individual surface properties

such as convex pockets where the catalyst resides, such as in Cab-osil®. All these different properties have an effect on the catalyst loading, steric constraints on reactant diffusion, transition states and intermediates, consequently altering the selectivity and activity from one catalyst to another. This can be observed in differences of selectivity when pore diameters are varied from 30 to 150 Å [46]. Not only does this affect the active site isolation when synthesizing the heterogeneous catalyst but also has an effect on reactant diffusion and the mechanistic course because of the spatial restrictions. Selectivity can be influenced by the constriction of space around the active site. In order to ascertain whether the catalyst is encapsulated inside the channels of the framework or on the outer surface, it is essential to understand the effect of the support. To ensure most of the active sites are located within the framework, a capping agent is introduced before attaching the amino acid. The capping agent is a bulky group, usually dichlorodiphenylsilane, which is added in a very small quantity. The bulky group binds to the outer surface of the silica framework by coupling to the easily accessible silanol groups on the outside. These silanol groups are now 'deactivated' so the amino acid can preferentially bind to the inside walls of the structure. Instead of using a capping agent to make sure the catalyst is incorporated, one can assume that the inner surface area is much greater than the outer surface, so the majority of the catalyst is immobilised inside the channels of the network. This is an adequate deduction, but if the support has a greater effect on the stereoselectivity of the product then having a minute amount of catalyst on the outer surface could have a great significance on the ee.

#### 2.4.3.4 Characterisation

Considering that the bulk of the material is the silica support, it is understandable that characterising the active catalyst is more difficult than previously perceived. Even more so since there is no metal present; this reduces the number of techniques that can be used. Structural information cannot be deduced from EPR and UV–Vis spectroscopy that can give a high-quality insight into the active site but reveal very little useful information in this case. A further difficulty for characterisation is that the catalyst is immobilised in the channels of the silica structure. Several techniques are surface sensitive so the fact that the catalyst is encapsulated and not on the outer surface renders these methods unusually unhelpful.

Basic experiments such as the Kaiser test can be used to detect if there is deprotected amino acid in the sample [63]. This is a simple colour change observation on addition of the two Kaiser reagents with heating at 120°C. The solution will turn deep blue in colour if there are free primary amines present. A quantitative value can be taken by measuring the absorbance of cleaved Fmoc adducts after the deprotection step. The intensity of the absorbance measured at  $\lambda_{\max}$  302 nm depends on the concentration of Fmoc adduct in solution. By working out the concentration of Fmoc-adducts using the Beer-Lambert law, the

amino acid concentration in the sample can be indirectly calculated, since for every cleaved Fmoc there must be one deprotected amino acid. As a result the amino acid/catalyst loading can be calculated and in turn gives the necessary quantities for turnover number (TON) and turnover frequency (TOF) to be derived when catalysis is carried out.

Another informative technique is to carry out elemental analysis. This gives the % mass of the varying elements contained in the sample; therefore an empirical formula can be deduced by working out the ratios between different elements. This is useful as it gives an insight into the catalyst loading and confirms the presence of the amino acid derivative but it does not offer proof that the organic moiety is incorporated in the channels of the framework. One way of substantiating this claim is by Brunauer–Emmett–Teller (BET) adsorption isotherms. Measuring the concentration of adsorbed probe molecules on a non-derivatized porous silica framework provides a specific surface area for the support before catalyst impregnation. Covalent attachment of the catalyst should give a smaller surface area, because now the surface available for the adsorption of small gaseous molecules has decreased due to the amino acid occupying significant space in the pores.

Further evidence for amino acid immobilisation can be sought by means of solid state NMR spectroscopy.  $^{13}\text{C}$  MAS NMR is a principal technique that confirms the presence of the specific amino acid by matching the corresponding peaks to that of the pure amino acid (Fig. 2.18). NMR is a valuable asset in characterisation methods, but in this case because the sample has only around 1% carbon content and only 1.1% of that is the spin active  $^{13}\text{C}$  isotope, this means that the amino acid is actually quite difficult to detect. From the spectra it is just possible to distinguish the peaks due to inequivalent carbon environments over the background noise. Using solid state NMR spectroscopy one can also determine if the organocatalyst is covalently attached to the silica surface or just adsorbed. This is achieved by measuring the spectrum of  $^{29}\text{Si}$ . If covalently attached, the NMR spectrum should show several peaks that indicate the presence of different silicon environments. A peak at around  $-100$  ppm is characteristic of  $(\text{Si}(\text{O}-))_4$  silicates, which are of the bulk material. Further peaks around  $-60$  ppm are typical of the silicon in the tether which is bound to the framework. Numerous peaks in the region of this chemical shift can be detected due to the varying number of ethoxy groups that have been grafted onto the support from each tether. These peaks are a clear indication of covalent immobilisation and are due to  $(\text{RSi}(\text{OEt})_2\text{O}-)$  and  $(\text{RSi}(\text{O}-)_2\text{OEt})$ .

Powder infrared (IR) spectroscopy is another powerful tool to characterise the immobilised catalyst. Again the absorbances identified are extremely weak due to the catalyst residing inside the channels but, nevertheless, absorbances are noticed though they are very weak. Typical absorbances are found at around  $3,300\text{ cm}^{-1}$  for O–H and N–H stretches and along with carbonyl stretching frequencies at  $\sim 1,700\text{ cm}^{-1}$ , C–H stretches are also detected just below  $3,000\text{ cm}^{-1}$  to confirm presence of the amino acid. IR spectroscopy can also give an insight as to whether the amino acid is covalently bound to the silica support or not. This is achieved by interpreting the absorbances  $\sim 1,000\text{ cm}^{-1}$  in the fingerprint region where Si–O

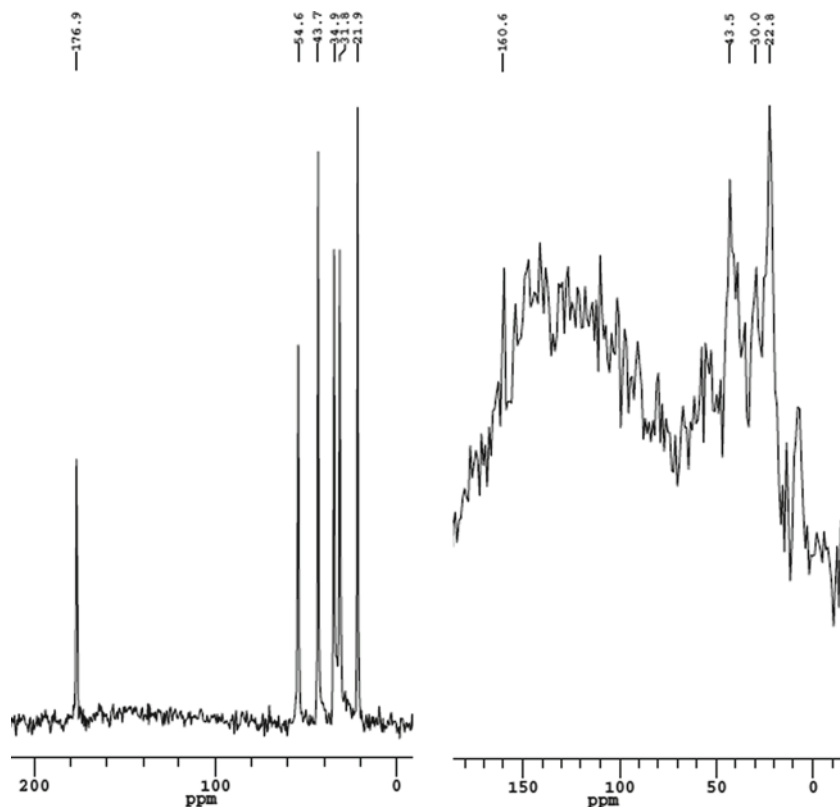

**Fig. 2.18**  $^{13}\text{C}$  MAS CP NMR of pure lysine (*left*) and immobilised lysine on porous 60 Å silica (*right*)

bonds absorb. Noticing extra peaks in this region suggests other Si–O environments. This can be accounted for the presence of Si in the tether that is bonded to different substituents when compared to the typical Si of the framework. The bulk Si of the support are all in a tetrahedral environment with four Si–O bonds whereas the Si of the tether either exists as  $\text{RCH}_2\text{Si}(\text{OSi})_2(\text{OEt})$  or  $\text{RCH}_2\text{Si}(\text{OSi})_3$ , confirming to varying Si–O bond strengths that will absorb at differing frequencies.

Collectively using these characterisation methods a conclusion can be adequately drawn regarding not only the presence of the amino acid, but its covalently attached heterogeneous nature.

#### 2.4.4 Heterogenised Amino Acids as Single-Site Catalysts

Immobilising amino acids in this way produces covalently anchored single-site heterogeneous catalysts for utilisation in asymmetric enamine catalysis. Enamine

catalysis is the reversible generation of an enamine, from a catalytic amount of amine and a carbonyl compound, as an intermediate step in addition and substitution reactions [64]. All amino acids follow this mode of catalysis because of the free amine group, with the additional benefit of the close proximity carboxylate group. The carboxylate functionality influences the configuration of the transition state and therefore gives rise to stereoselectivity in the final product. An example of enamine catalysis is in the asymmetric aldol reaction and this is why amino acids, especially that of proline, have been employed as catalysts for this type of reaction [42] (Fig. 2.19). The aldol reaction is a fundamental C–C bond forming reaction and is used for the synthesis of complex natural products and drug molecules.

Many reports of different aldehydes have been used in the catalysed aldol reaction along with specific aldolizations such as Hajos-Parrish reactions [65,66] and intermolecular aldolizations with cyclic ketone donors [67]. The scope for these bio-derived supports is extensive. Any reaction that uses an organocatalyst that goes via an enamine intermediate has the potential to be catalysed by these amino acid derivatized frameworks. Intermolecular and intramolecular Michael reactions have been catalysed by amino acids in the homogeneous state [68,69] so these heterogeneous catalysts have great potential in replicating and improving these results. Reactions that include the  $\alpha$ -amination,  $\alpha$ -oxygenation and  $\alpha$ -halogenation of carbonyl compounds have also been catalysed by amino acids [70–72] in solution so these can potentially

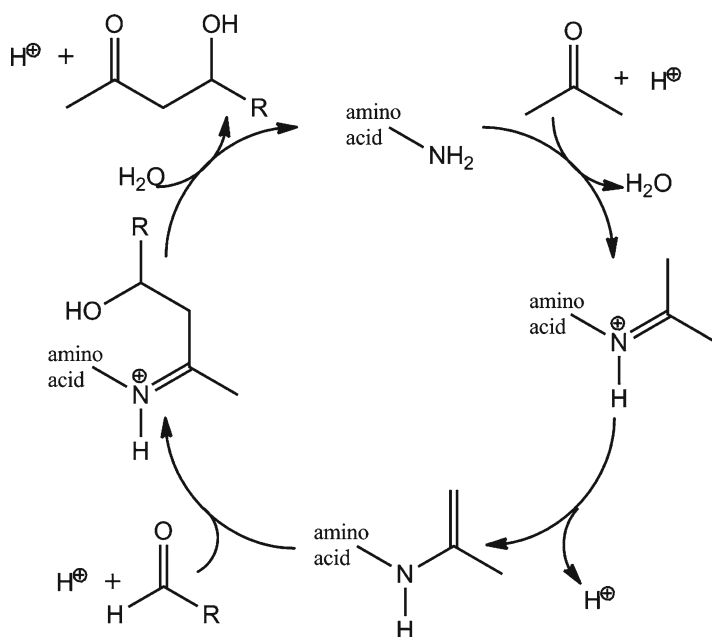

**Fig. 2.19** Catalytic cycle of an asymmetric aldol reaction via an enamine intermediate

undergo the transformations assisted by the bio-derived frameworks with greater efficiency.

## 2.4.5 Summary

The use of amino acids as organocatalysts has generated widespread interest in recent years. They have been used to catalyse some of the most fundamental C–C bond forming reactions, such as the aldol and Mannich reactions, with high stereoselectivity and yields. These organocatalysts still suffer drawbacks in the homogeneous state and through suitable immobilisation techniques these disadvantages can be overcome with complimentary yields and selectivities. Covalently anchoring amino acids to silica through the side chain functionalities, offers accomplished routes to bio-derived frameworks that can be utilized as catalysts for specific transformations in fine chemical production.

## References

1. Holm RH, Kennepohl P, Solomon EI (1996) *Chem Rev* 96:2239–2314
2. Que L, Tolman WB (2008) *Nature* 455:333–340
3. Shan X, Que L (2006) *J Inorg Biochem* 100:421–433
4. Meunier B, de Visser SP, Shaik S (2004) *Chem Rev* 104:3947–3980
5. Neidig ML, Solomon EI (2005) *Chem Commun* 47:5843–5863
6. Zhang J, Zheng H, Groce SL, Lipscomb JD (2006) *J Mol Catal A Chem* 251:54–65
7. Solomon EI, Chen P, Metz M, Lee SK, Palmer AE (2001) *Angew Chem Int Ed* 40:4570–4590
8. Lieberman RL, Rosenzweig AC (2005) *Dalton Trans* 21:3390–3396
9. Klinman JP (1996) *Chem Rev* 96:2541–2561
10. Whittaker JW (2003) *Chem Rev* 103:2347–2363
11. Matoba Y, Kumagai T, Yamamoto A, Yoshitsu H, Sugiyama M (2006) *J Biol Chem* 281:8981–8990
12. Eicken C, Krebs B, Sacchettini JC (1999) *Curr Opin Struct Biol* 9:677–683
13. Yamauchi O, Odani A, Takani M (2002) *Dalton Trans* 18:3411–3421
14. Suzuki K, Oldenburg PD, Que L Jr (2008) *Angew Chem Int Ed Engl* 47:1887–1889
15. Luechinger M, Kienhöfer A, Pirngruber GD (2006) *Chem Mater* 18:1330–1336
16. Kerman K, Kraatz HB (2008) *Angew Chem Int Ed* 47:6522–6524
17. Wight AP, Davis ME (2002) *Chem Rev* 102:3589–3614
18. Yang H, Zhang G, Hong X, Zhu Y (2004) *Micropor Mesopor Mater* 68:119–125
19. Luechinger M, Prins R, Pirngruber GD (2005) *Micropor Mesopor Mater* 85:111–118
20. Walcarius A, Etienne M, Lebeau B (2003) *Chem Mater* 15:2174–2180
21. Merrifield RB (1963) *J Am Chem Soc* 85:2149–2154
22. Pirngruber GD, Frunz L, Luechinger M (2009) *Phys Chem Chem Phys* 11:2928–2938
23. Derouane EG (2002) *Cat Tech* 6:11–13
24. Raja R, Thomas JM (2002) *J Mol Catal* 181:3–14
25. Raja R, Ratnasamy P (1997) *J Catal* 170:244–253
26. Raja R, Ratnasamy P (1997) *Catal Lett* 48:1–10
27. De Vos DE, Sels BF, Jacobs PA (2002) *Cat Tech* 6:14–29

28. Raja R, Ratnasamy P (1996) *Applied Catal A* 143:145–158
29. Raja R, Ratnasamy P (1996) *Applied Catal A* 158:L7–L15
30. Raja R, Thomas JM (2001) *Chem Record* 1:448–466
31. Weckhuysen BM, Verberckmoes AA, Fu L, Schoonheydt RA (1996) *J Phys Chem* 100:9456–9461
32. Fan B, Li H, Fan W, Jin Ch, Li R (2008) *Appl Catal A Gen* 340:67–75
33. Balkus KJ Jr, Eissa M, Levado R (1995) *J Am Chem Soc* 117:10753–10754
34. Dzierzak J, Lefenfeld M, Raja R (2009) *Top Catal* 52:1669–1676
35. Grommen R, Manikandan P, Gao Y, Shane T, Shane JJ, Schoonheydt RA, Weckhuysen BM, Goldfarb D (2000) *J Am Chem Soc* 122:11488–11496
36. <http://www.iza-structure.org/databases/>
37. Mateo Marti E, Barlow SM, Haq S, Raval R (2002) *Surface Sci* 501:191–202
38. Bordiga S, Buzzoni R, Geobaldo F, Lamberti C, Giannelo E, Zecchina A, Leofanti G, Petrini G, Tozzola G, Vlaic G (1996) *J Catal* 158:486–501
39. Zhilinskaya EA, Delahay G, Mauvezin M, Coq B, Aboukais A (2003) *Langmuir* 19:3596–3602
40. Raja R, Thomas JM, Greenhill-Hooper M, Doukova V (2007) *Chem Comm* 1924–1926
41. Raja R (2009) *Top Catal* 52:322–332
42. List B, Lerner RA, Barbas CF (2000) *J Am Chem Soc* 122:2395–2396
43. Ramachary DB, Chowdari NS, Barbas CF (2000) *Tet Lett* 43:6743–6746
44. List B (2000) *J Am Chem Soc* 122:9336–9337
45. Miao WS, Chan TH (2006) *Adv Synt Catal* 348:1711–1718
46. Raja R, Thomas JM, Jones MD, Johnson BFG, Vaughan DEW (2003) *J Am Chem Soc* 125:14982–14983
47. Shen ZX, Ma JM, Liu YH, Jia CJ, Li M, Zhang YW (2005) *Chirality* 17:556–558
48. Liu K, Haeussinger D, Woggon WD (2007) *Synlett* 14:2298–2300
49. Gruttadauria M, Riela S, Aprile C, Lo Meo P, D’Anna F, Noto R (2006) *Adv Syn Catal* 348:82–92
50. Aprile C, Giacalone F, Gruttadauria M, Marculescu AM, Noto R, Revell JD, Wennemers H (2007) *Green Chem* 9:1328–1334
51. Bellis E, Kokotos G (2005) *J Mol Catal Chem* 241:166–174
52. Benaglia M, Celentano G, Cozzi F (2001) *Adv Syn Catal* 343:171–173
53. Gu LQ, Wu YY, Zhang YZ, Zhao G (2007) *J Mol Catal A Chem* 263:186–194
54. Font D, Jimeno C, Pericas MA (2006) *Org Lett* 8:4653–4655
55. Giacalone F, Gruttadauria M, Marculescu AM, Noto R (2007) *Tet Lett* 48:255–259
56. Akagawa K, Sakamoto S, Kudo K (2005) *Tet Lett* 46:8185–8187
57. Revell JD, Gantenbein D, Krattiger P, Wennemers H (2006) *Biopolymers* 84:105–113
58. Krattiger P, Kovasy R, Revell JD, Ivan S, Wennemers H (2005) *Org Lett* 7:1101–1103
59. Bayer E (1991) *Angew Chem Int Ed Engl* 30:113–129
60. Jones MD, Raja R, Thomas JM, Johnson BFG (2003) *Top Catal* 25:71–79
61. Jones MD, Raja R, Thomas JM, Johnson BFG, Lewis DW, Rouzaud JM, Harris KD (2003) *Angew Chem Int Ed* 42:4326–4331
62. Calderon F, Fernandez R, Sanchez F, Fernandez-Mayoralas A (2005) *Adv Syn Catal* 347:1395–1403
63. Kaiser K, Colescott RL, Bossinger CD, Cook PI (1970) *Anal Biochem* 34:595
64. Mukherjee S, Yang JW, Hoffmann S, List B (2007) *Chem Rev* 107:5471–5569
65. Hoang L, Bahmanyar S, Houk KN, List B (2003) *J Amer Chem Soc* 125:16–17
66. Northrup AB, MacMillan DWC (2002) *J Amer Chem Soc* 124:6798–6799
67. List B, Pojarliev P, Castell C (2001) *Org Lett* 3:573–575
68. Kozikowski AP, Mugrage BB (1989) *J Org Chem* 54:2274–2275
69. List B, Pojarliev P, Martin HJ (2001) *Org Lett* 3:2423–2425
70. List B (2002) *J Amer Chem Soc* 124:5656–5657
71. Zhong GF (2003) *Angew Chem Int Ed* 42:4247–4250
72. Enders D, Hüttl MRM (2005) *Synlett* 6:991–993



<http://www.springer.com/978-90-481-3695-7>

Heterogenized Homogeneous Catalysts for Fine  
Chemicals Production

Materials and Processes

Barbaro, P.; Liguori, F. (Eds.)

2010, XVIII, 462 p., Hardcover

ISBN: 978-90-481-3695-7